

## 圆杆数显卡尺

## 111系列

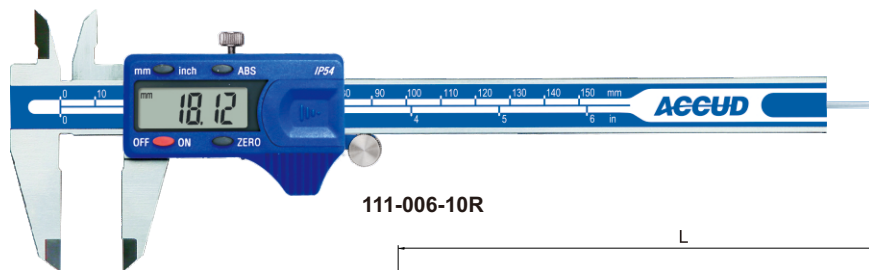

111-006-10R

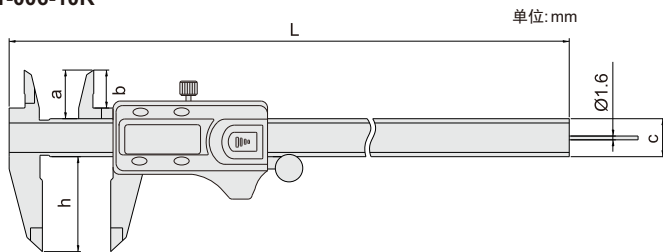

- ◆ 符合JJG通用卡尺国家计量检定规程
- ◆ 圆杆深度杆, 便于测量小孔深度
- ◆ 分辨率: 0.01mm/0.0005"
- ◆ 按键功能: 开关机, 置零, 公英制转换, 绝对相对测量转换
- ◆ 带数据输出(数据线货号:100-03或100-04)
- ◆ 自动关机, 滑动开机
- ◆ 不锈钢尺身

圆杆深度杆

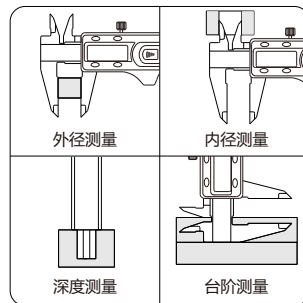
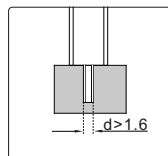

货号	量程	精度	滚轮	a	b	c	h	L
111-006-10R	0-150mm/0-6"	±0.03mm	有	21	16	16	40	236
111-006-10RW	0-150mm/0-6"	±0.03mm	无	21	16	16	40	236