

游标卡尺

127系列

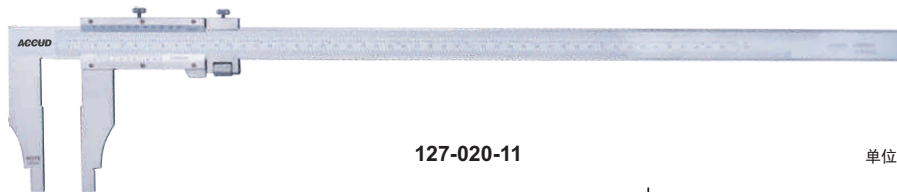

127-020-11

单位: mm

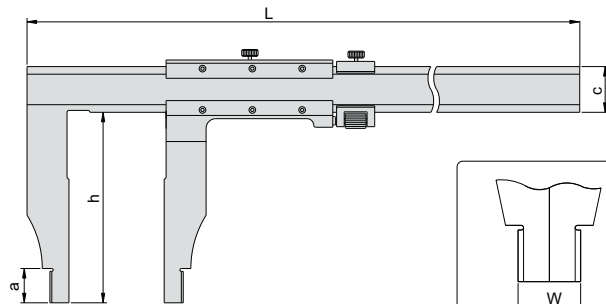

- ◆ 分度值:0.02mm/0.001"
- ◆ 带微调框
- ◆ 不锈钢尺身
- ◆ 刻度面镀暗铬

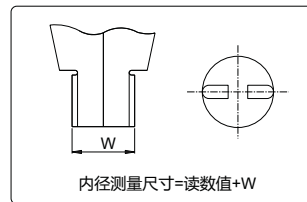

货号	量程	精度	a	c	h	w	L
127-012-11	0-300mm/0-12"	±0.05mm	12	20	75	10	410
127-020-11	0-500mm/0-20"	±0.05mm	18	24	100	20	670
127-024-11	0-600mm/0-24"	±0.05mm	18	24	100	20	770
127-032-11	0-800mm/0-32"	±0.08mm	24	32	150	20	1020
127-040-11	0-1000mm/0-40"	±0.08mm	24	32	140	20	1216
127-060-11	0-1500mm/0-60"	±0.11mm	24	42	180	20	1830
127-080-11	0-2000mm/0-80"	±0.14mm	24	42	200	20	2320

