

对接焊接规

746

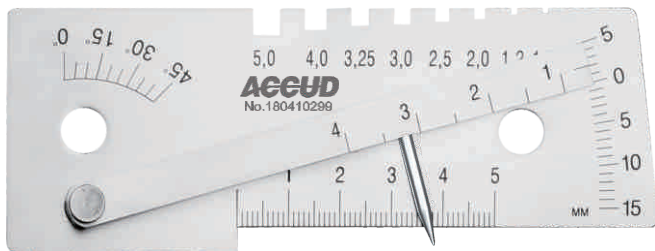

单位:mm

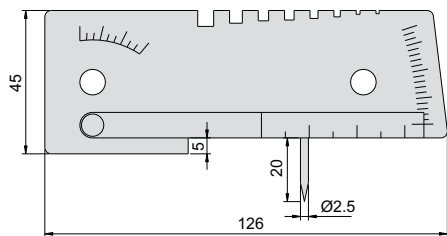

◆ 不锈钢尺身

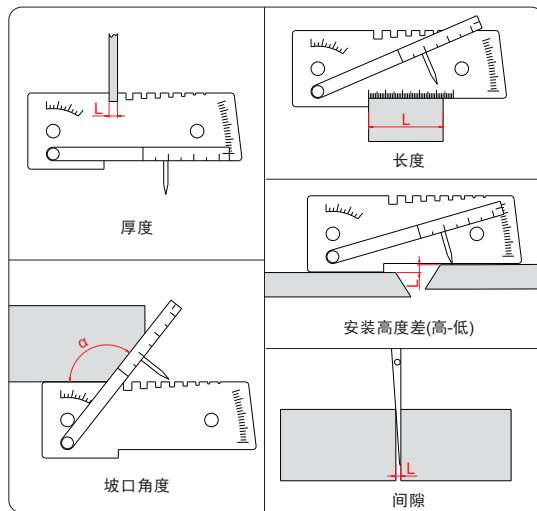

型号	测量项目	量程	分度值	精度
746-050-01	安装误差 (高/低)	-5mm-15mm	1mm	±0.5mm
	坡口角度	0°-45°	5°	±2.5°
	长度	0-50mm	1mm	±0.5mm
	间隙尺	1-4mm	0.5mm	±0.25mm
	厚度	1, 1.2, 2.0, 2.5, 3.0, 3.25, 4.0, 5.0mm	—	±0.1mm