

数显焊接规

970

- ◆ 按键: 置零, mm/inch, 开关键
- ◆ 不锈钢尺身

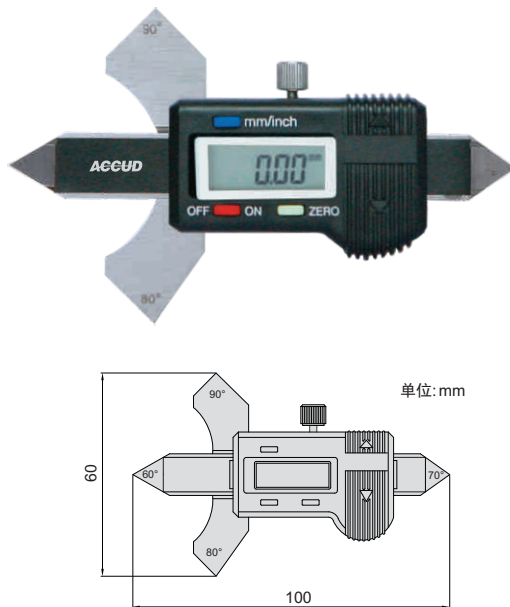
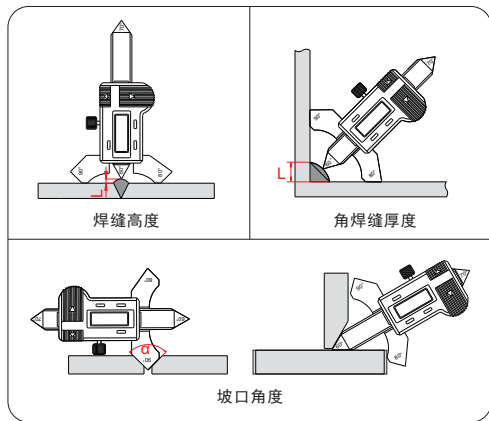

货号	厚度范围	精度	分辨率	用途
970-010-11	0-10mm	±0.03mm	0.01mm/0.0005"	测量焊缝高度
	0-20mm	±0.1mm	0.01mm/0.0005"	测量角焊缝厚度
	60°, 70°, 80°, 90°	±1°	—	测量坡口角度

