

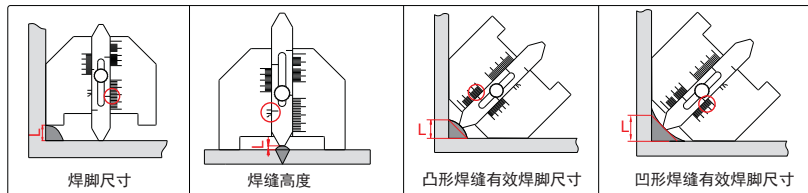

焊接规

979

◆ 不锈钢材料

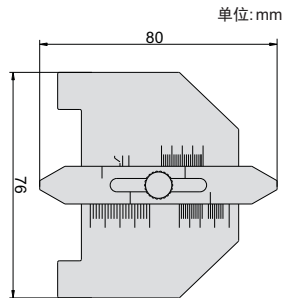
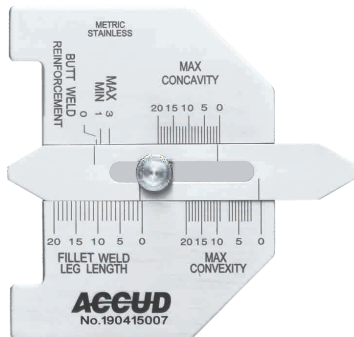

货号	量程	分度值	精度	测量
979-020-01	0-20mm	1mm	±0.5mm	焊脚尺寸
	0-3mm	—	±0.5mm	焊缝高度
	0-20mm	1mm	±0.5mm	凸形焊缝有效焊脚尺寸
	0-20mm	1mm	±0.5mm	凹形焊缝有效焊脚尺寸